



SPEO CO., LTD

📍 Add.: No. 18 East 11th Rd. Changsha Area of China (Hunan) Pilot
Free Trade Zone 410100
🌐 www.speostraddlecarrier.com
☎ Tel.: +86 178 7195 1227
✉ Email: speostraddlecarrier@gmail.com

SPEO®

SPEO CO., LTD

HKY SERIES STRADDLE CARRIER



—
35T Standard Container Straddle
Carrier

20-220T Custom Design Straddle
Carrier



About Speo

SPEO CO., LTD

Since 2017, SPEO CO., LTD. started in the straddle carrier industry and launched products and solutions such as straddle carriers, automatic container dumping machines, and fully automatic coal unloading systems with independent intellectual property rights.

SPEO is fully connected with ports, Non-standard customization requirements for material handling equipment from docks to factories.

The company's R&D team actively challenges new scenarios and new heights. Its comprehensive strength has been awarded by BYD, CATL, Shandong Port Group, State Grid, China Southern Power Grid, ZPMC, Jindadi Chemical and many other well-known companies in the industry.



Less Machine Weight



Compared to 80T Reach Stacker, SPEO Straddle Carrier main machine only weighs 18T. The light weight provides many advantages in cost and daily consumption.

Less Ground Requirement

SPEO Straddle Carrier requires no reinforced concrete ground due to its low ground pressure and large solid puncture-proof tyres. It could walk on compacted stone, bitumen and light concrete.



Less Energy Consumption

The light weight insures the energy consumption much lower than Reach Stacker. And save operation cost at a dramatic level.

Less Budget

SPEO Straddle Carrier is a cheaper choice from purchasing to daily consumption and maintenance than Reach Stacker and other brands straddle carrier.

More Balanced Design

The straddle carrier design makes the gravity point remains in the middle of the machine. And the Balancing Adjustment System can adjust the side position of the load.

The genius Stabiliser System avoids tyre suspension on uneven ground conditions or slopes.



More Options

SPEO Straddle Carrier could be custom made according to our customer needs with multiple options. We could fit all kinds of oversized objects like steel structures, pre-fab houses, battery bays, precast girders and other precast concrete products.

Battery Powered

A Lithium iron phosphate battery set with more than 150kwh electric power could replace the diesel engine. Together with a Permanent Magnet Synchronous Motor. The charging of battery only takes a few hours and could work a whole day. The battery powered model provides No air pollution, Low noise, Green Energy in the working area with lower energy consumption than diesel.



Customized Oversized Loads

Straddle Carrier could be made into different dimensions with different spreaders according to the size and weight of your product. No matter it's a large or long product. Or warehouse with a low doorway. SPEO experienced engineers will assist you with the best solutions.

Spreaders

SPEO Straddle Carrier not only have automatic spreaders for 20' 40' 45' standard containers, but also customize different spreaders with chains, belts, locks and all creative designs.



Tyres

According to your requirement, SPEO can offer designs on different tyre format with 4/6/8 or more tyres for the Straddle Carrier to fit your ground conditions.

Remote Control

A remote control system is optional with or without a driver cabin for a better visual sight and easier rigging alignment.



Weight Measurement System

To compliant local regulations or for your own needs, Weight Measurement System is optional with data shown in kgs or lbs.

360°Cameras

360° camera layout improves the visual ability while avoiding the bad weather outside of the cabin

Collision Alert

The alert will ring when object getting closer to the Straddle Carrier, to ensure safety of the equipment.



Hydraulic Balancing

With hydraulic pressure to ensure all the tires are loaded with same pressure.



Standard Specification HKY3532A

PARAMETERS	HKY3533A
Lifting weight	35T
Dimension(Length*Width*Height)	7100*5100*6050 (mm)
Inner width	3200mm
Wheel base	6000mm
Duplex lifting height	1550mm
Min.Ground clearance	240mm
Machine weight	18T
Engine(China Stagelll)	Cummins
Travel Pump	Hytek/Linde/Danfoss
Travel speed(Unladen)	7km/h
Travel Speed(Laden)	5km/h
Turning Radius	7000mm
Gradeability(Unladen/Laden)	10%/5%
Manipulation	Steering wheel (Optional remote control)
Tires	1100(02PCs)+1300 Solid Tire (02PCs)
Lifting Tools	Automatic Spreader

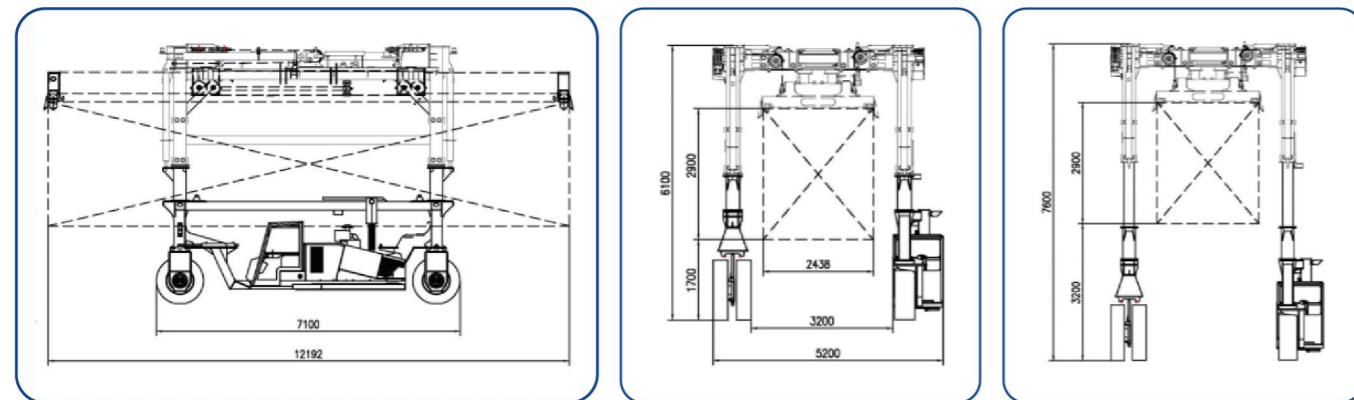

Honorable Suppliers



Honorable Clients

